



# M300 Series Data Acquisition/ Switch System

- Up to 320 switch channels per mainframe, save on cost of ownership
- Can be run without PC
- USB logging
- Interval scanning with storage of up to 100,000 time-stamped readings
- 8 kinds of cards supported
- 6½ digits DMM can be enabled/disabled in any of slots
- Standard SCPI commands
- Math statistics: AVG, MAX, MIN, SDEV
- 4.3' TFT LCD
- Powerful PC software
- Full Interfaces supported: USB Device, USB Host, GPIB, LAN(LXI-Core 2011 Device), RS232

M300 Series Data Acquisition/Switch System with modular structure, which combines precision measurement capability with flexible signal connections, can provide versatile solutions for the applications with multiple points or signals to be tested in product performance test during R&D phase as well as automatic test during production process.

# M300 Series Data Acquisition/Switch System

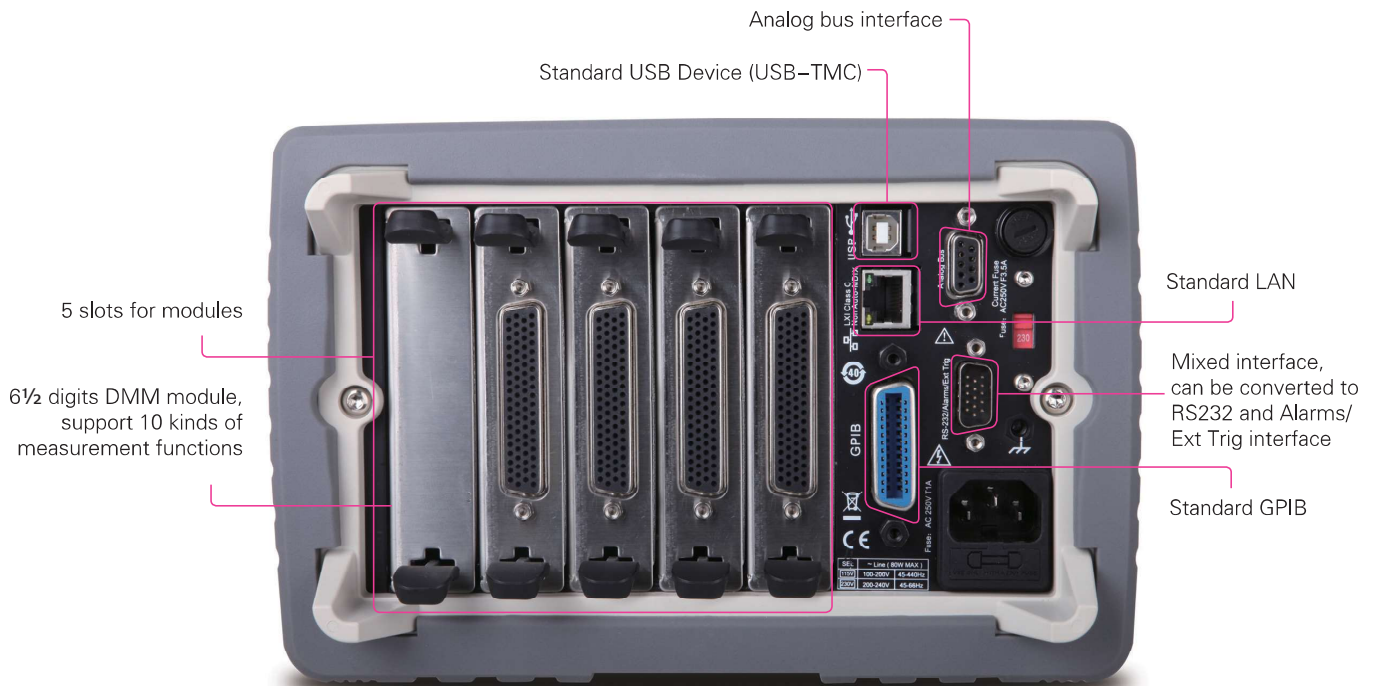
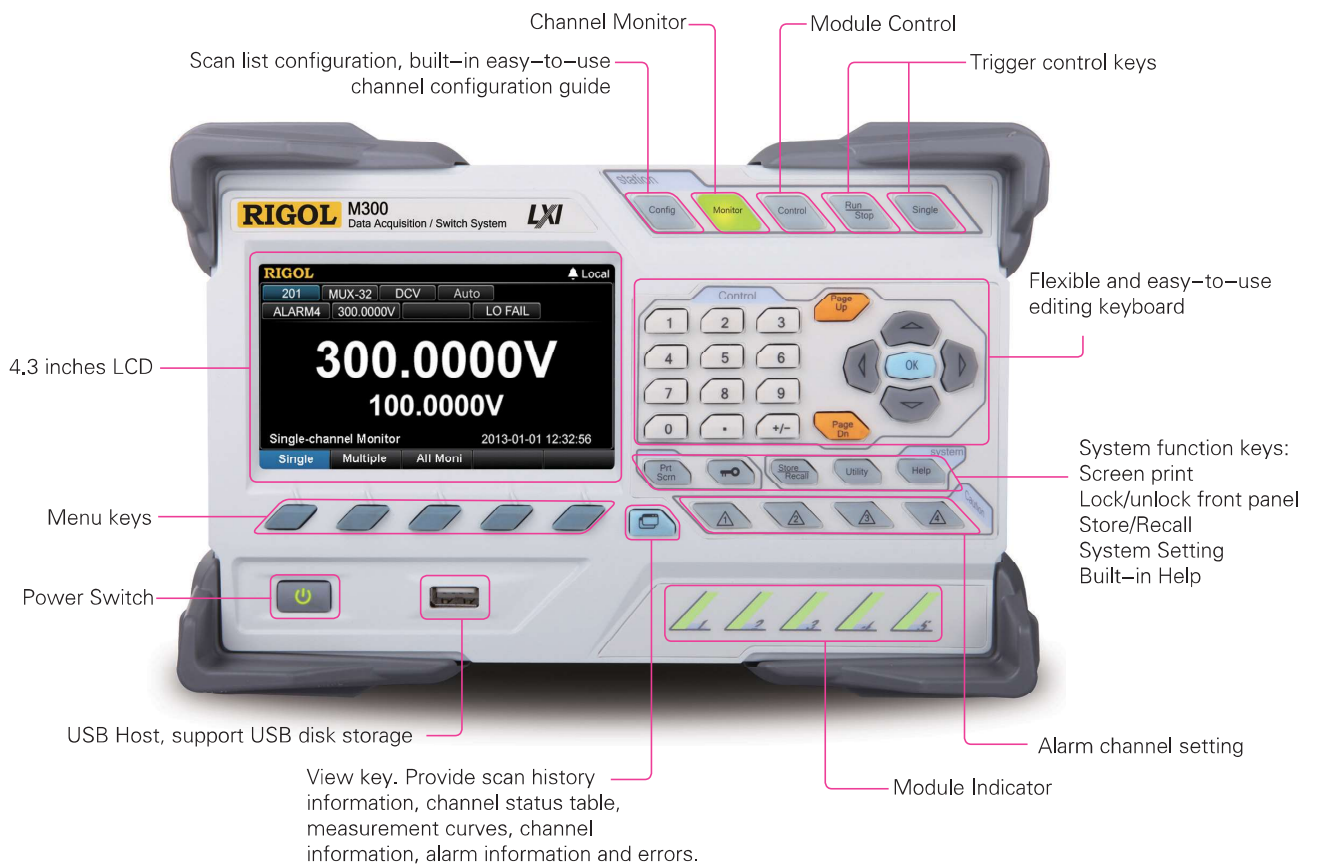

Product Dimensions: Width X Height X Depth=239.0mm×159.0 mm×373.4 mm Weight: 5.7 kg(Without Package)

## Multiplexers Selection Guide

M300 provides five kinds of multiplexers and five kinds of external terminal blocks which are used to connect signals. These multiplexers support three types of connection modes: 1-wire mode, 2-wire mode and 4-wire mode. You can select your desired multiplexer and terminal block by referring to the following table.

		MC3120	MC3132	MC3164	MC3324
Number of Channels		20	32	64	20+4
		2-wire mode or 4-wire mode	2-wire mode or 4-wire mode	1-wire mode	2-wire mode or 4-wire mode
Scan Speed		60Ch/s	60Ch/s	60Ch/s	60Ch/s
Terminal Block		M3TB20	M3TB32	M3TB64	M3TB24
DC Voltage		✓	✓	✓	✓
AC Voltage		✓	✓	✓	✓
DC Current					✓
AC Current					✓
2WR		✓	✓	✓	✓
4WR		✓	✓		✓
Frequency		✓	✓	✓	✓
Period		✓	✓	✓	✓
Temperature	TC	✓	✓		✓
	RTD	✓	✓	✓	✓
	RTD 4W	✓	✓		✓
	Thermistor	✓	✓	✓	✓
Any Sensor	DC Voltage	✓	✓	✓	✓
	DC Current				✓
	2WR	✓	✓	✓	✓
	4WR	✓	✓		✓
	Frequency	✓	✓	✓	✓

### MC3120 20-Channel Multiplexer

- 20-channel multiplexer
- All 20 channels switch both HI and LO inputs
- Support 4-wire measurement
- The signal to be tested is connected through the M3TB20 terminal block
- Can be connected with MC3065

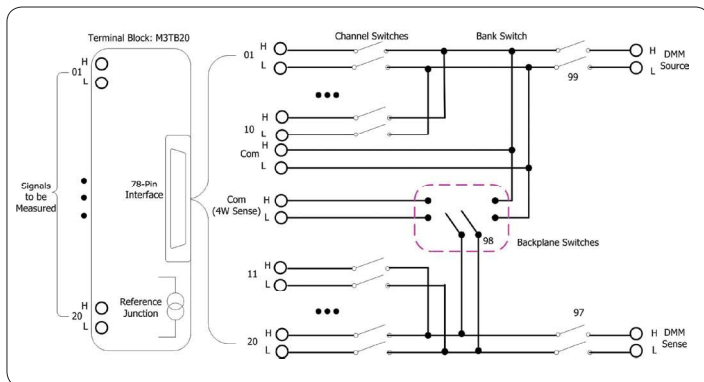

## ► Specifications

### DC Characteristics

Accuracy Specifications:  $\pm$  (% of reading + % of range)<sup>[1]</sup>

Function	Range <sup>[2]</sup>	Test Current or Load Voltage	24 Hour <sup>[3]</sup> T <sub>CAL</sub> °C $\pm$ 1°C	90 Day T <sub>CAL</sub> °C $\pm$ 5°C	1 Year T <sub>CAL</sub> °C $\pm$ 5°C	Temperature Coefficient 0°C to (T <sub>CAL</sub> °C -5°C) (T <sub>CAL</sub> °C +5°C) to 50°C
DC Voltage	200.0000mV	–	0.0020 + 0.0020	0.0030 + 0.0025	0.0040 + 0.0025	0.0005 + 0.0005
	2.000000V	–	0.0015 + 0.0005	0.0020 + 0.0006	0.0035 + 0.0006	0.0005 + 0.0001
	20.00000V	–	0.0020 + 0.0004	0.0030 + 0.0005	0.0040 + 0.0005	0.0005 + 0.0001
	200.0000V	–	0.0020 + 0.0006	0.0040 + 0.0006	0.0050 + 0.0006	0.0005 + 0.0001
	300.000V	–	0.0020 + 0.0006	0.0040 + 0.0010	0.0055 + 0.0010	0.0005 + 0.0001
DC Current	200.0000 $\mu$ A	<0.03V	0.010 + 0.012	0.040 + 0.015	0.050 + 0.015	0.0020 + 0.0030
	2.000000mA	<0.25V	0.007 + 0.003	0.030 + 0.003	0.050 + 0.003	0.0020 + 0.0005
	20.00000mA	<0.07V	0.007 + 0.012	0.030 + 0.015	0.050 + 0.015	0.0020 + 0.0020
	200.0000mA	<0.7V	0.010 + 0.002	0.030 + 0.003	0.050 + 0.003	0.0020 + 0.0005
	1.000000A	<0.12V	0.050 + 0.020	0.080 + 0.020	0.100 + 0.020	0.0050 + 0.0010
Resistance <sup>[4]</sup>	200.0000 $\Omega$	1mA	0.0030 + 0.0030	0.008 + 0.004	0.010 + 0.004	0.0006 + 0.0005
	2.000000k $\Omega$	1mA	0.0020 + 0.0005	0.008 + 0.001	0.010 + 0.001	0.0006 + 0.0001
	20.00000k $\Omega$	100 $\mu$ A	0.0020 + 0.0005	0.008 + 0.001	0.010 + 0.001	0.0006 + 0.0001
	200.0000k $\Omega$	10 $\mu$ A	0.0020 + 0.0005	0.008 + 0.001	0.010 + 0.001	0.0006 + 0.0001
	1.000000M $\Omega$	2 $\mu$ A	0.002 + 0.001	0.010 + 0.001	0.012 + 0.001	0.0010 + 0.0002
	10.00000M $\Omega$	200nA	0.015 + 0.001	0.030 + 0.001	0.040 + 0.001	0.0030 + 0.0004
	100.0000M $\Omega$	200nA    10M $\Omega$	0.300 + 0.010	0.800 + 0.010	0.800 + 0.010	0.1500 + 0.0002

NOTE: [1] Specifications are for 90-minute warm-up and 100 PLC integration time.

[2] 10% overrange on all ranges.

[3] Relative to calibration standards.

[4] Specifications are for 4-wire resistance measurement. Add 3  $\Omega$  additional error in 2-wire resistance measurement.

### Measuring Characteristics

DC Voltage	
Input Impedance	200mV, 2V, 20V ranges: 10M $\Omega$ or >10G $\Omega$ (For these ranges, input beyond $\pm$ 26 V are clamped through 106 k $\Omega$ ) 200V and 300V ranges: 10M $\Omega$ $\pm$ 1%
Input Protection	300V
Input Offset Current	50pA, at 25°C, typical
CMRR (common mode rejection ratio)	140 dB for 1 k $\Omega$ unbalanced resistance in LO lead, $\pm$ 300 VDC peak maximum.
Resistance	
Measurement Method	4-wire or 2-wire resistance Current source referenced to LO input
Open-circuit Voltage	Limited to <10 V
Max. Lead Resistance (4-wire)	10% of range per lead for 200 $\Omega$ and 2 k $\Omega$ ranges, 1 k $\Omega$ per lead on all other ranges
Input Protection	300V on all ranges
Offset Compensation	Available on 200 $\Omega$ , 2 k $\Omega$ and 20 k $\Omega$ ranges.
DC Current	
Shunt Resistor	100 $\Omega$ for 200 $\mu$ A, 2 mA 1 $\Omega$ for 20 mA, 200 mA 0.1 $\Omega$ for 1 A
Auto Zero OFF Operation (typical value)	
Following instrument warm-up at the environment temperature $\pm$ 1°C and <5 minutes, add 0.0001 % range + 2 $\mu$ V error for DCV and 2 m $\Omega$ error for resistance.	
Settling Considerations	
Reading settling times are affected by source impedance, cable dielectric characteristics and input signal changes. The default measurement delay can ensure the correctness of the first reading for most measurements.	
Measurement Considerations	
Teflon or other high-impedance, low-dielectric absorption wire insulation is recommended for these measurements.	

## AC Characteristics

Accuracy Specifications:  $\pm$  (% of reading + % of range)<sup>[1]</sup>

Function	Range <sup>[2]</sup>	Frequency Range	24 Hour <sup>[3]</sup> T <sub>CAL</sub> °C $\pm$ 1°C	90 Day T <sub>CAL</sub> °C $\pm$ 5°C	1 Year T <sub>CAL</sub> °C $\pm$ 5°C	Temperature Coefficient 0°C to (T <sub>CAL</sub> °C -5°C ) (T <sub>CAL</sub> °C +5°C ) to 50°C
True RMS AC Voltage <sup>[4]</sup>	200.0000mV	3Hz– 5Hz	1.00 + 0.03	1.00 + 0.04	1.00 + 0.04	0.100 + 0.004
		5Hz–10Hz	0.35 + 0.03	0.35 + 0.04	0.35 + 0.04	0.035 + 0.004
		10Hz–20kHz	0.04 + 0.03	0.05 + 0.04	0.06 + 0.04	0.005 + 0.004
		20kHz–50kHz	0.10 + 0.05	0.11 + 0.05	0.12 + 0.05	0.011 + 0.005
		50kHz–100kHz	0.55 + 0.08	0.60 + 0.08	0.60 + 0.08	0.060 + 0.008
		100kHz– 300kHz	4.00 + 0.50	4.00 + 0.50	4.00 + 0.50	0.20 + 0.02
	2.000000V	3Hz–5Hz	1.00 + 0.02	1.00 + 0.03	1.00 + 0.03	0.100 + 0.003
		5Hz–10Hz	0.35 + 0.02	0.35 + 0.03	0.35 + 0.03	0.035 + 0.003
		10Hz–20kHz	0.04 + 0.02	0.05 + 0.03	0.06 + 0.03	0.005 + 0.003
		20kHz–50kHz	0.10 + 0.04	0.11 + 0.05	0.12 + 0.05	0.011 + 0.005
		50kHz–100kHz	0.55 + 0.08	0.60 + 0.08	0.60 + 0.08	0.060 + 0.008
		100kHz–300kHz	4.00 + 0.50	4.00 + 0.50	4.00 + 0.50	0.20 + 0.02
	20.00000V	3Hz–5Hz	1.00 + 0.03	1.00 + 0.04	1.00 + 0.04	0.100 + 0.004
		5Hz–10Hz	0.35 + 0.03	0.35 + 0.04	0.35 + 0.04	0.035 + 0.004
		10Hz–20kHz	0.04 + 0.04	0.07 + 0.04	0.08 + 0.04	0.008 + 0.004
		20kHz– 50kHz	0.10 + 0.05	0.12 + 0.05	0.15 + 0.05	0.012 + 0.005
		50kHz–100kHz	0.55 + 0.08	0.60 + 0.08	0.60 + 0.08	0.060 + 0.008
		100kHz–300kHz	4.00 + 0.50	4.00 + 0.50	4.00 + 0.50	0.20 + 0.02
	200.0000V	3Hz–5Hz	1.00 + 0.02	1.00 + 0.03	1.00 + 0.03	0.100 + 0.003
		5Hz–10Hz	0.35 + 0.02	0.35 + 0.03	0.35 + 0.03	0.035 + 0.003
		10Hz–20kHz	0.04 + 0.02	0.07 + 0.03	0.08 + 0.03	0.008 + 0.003
		20kHz–50kHz	0.10 + 0.04	0.12 + 0.05	0.15 + 0.05	0.012 + 0.005
		50kHz–100kHz	0.55 + 0.08	0.60 + 0.08	0.60 + 0.08	0.060 + 0.008
		100kHz–300kHz	4.0 + 0.50	4.0 + 0.50	4.0 + 0.50	0.20 + 0.02
300.000V	3Hz–5Hz	1.00 + 0.02	1.00 + 0.03	1.00 + 0.03	0.100 + 0.003	
	5Hz–10Hz	0.35 + 0.02	0.35 + 0.03	0.35 + 0.03	0.035 + 0.003	
	10Hz–20kHz	0.04 + 0.02	0.07 + 0.03	0.08 + 0.03	0.008 + 0.003	
	20kHz–50kHz	0.10 + 0.04	0.12 + 0.05	0.15 + 0.05	0.012 + 0.005	
	50kHz–100kHz	0.55 + 0.08	0.60 + 0.08	0.60 + 0.08	0.060 + 0.008	
	100kHz–300kHz	4.0 + 0.50	4.0 + 0.50	4.0 + 0.50	0.20 + 0.02	
True RMS AC Current <sup>[5]</sup>	200.0000 $\mu$ A	3Hz–5Hz	1.10 + 0.06	1.10 + 0.06	1.10 + 0.06	0.200 + 0.006
		5Hz–10Hz	0.35 + 0.06	0.35 + 0.06	0.35 + 0.06	0.100 + 0.006
		10Hz–5kHz	0.15 + 0.06	0.15 + 0.06	0.15 + 0.06	0.015 + 0.006
		5kHz–10kHz	0.35 + 0.70	0.35 + 0.70	0.35 + 0.70	0.030 + 0.006
	2.000000mA	3Hz–5Hz	1.00 + 0.04	1.00 + 0.04	1.00 + 0.04	0.100 + 0.006
		5Hz–10Hz	0.30 + 0.04	0.30 + 0.04	0.30 + 0.04	0.035 + 0.006
		10Hz–5kHz	0.12 + 0.04	0.12 + 0.04	0.12 + 0.04	0.015 + 0.006
		5kHz–10kHz	0.20 + 0.25	0.20 + 0.25	0.20 + 0.25	0.030 + 0.006
	20.00000mA	3Hz–5Hz	1.10 + 0.06	1.10 + 0.06	1.10 + 0.06	0.200 + 0.006
		5Hz–10Hz	0.35 + 0.06	0.35 + 0.06	0.35 + 0.06	0.100 + 0.006
		10Hz–5kHz	0.15 + 0.06	0.15 + 0.06	0.15 + 0.06	0.015 + 0.006
		5kHz–10kHz	0.35 + 0.70	0.35 + 0.70	0.35 + 0.70	0.030 + 0.006
	200.0000mA	3Hz–5Hz	1.00 + 0.04	1.00 + 0.04	1.00 + 0.04	0.100 + 0.006
		5Hz–10Hz	0.30 + 0.04	0.30 + 0.04	0.30 + 0.04	0.035 + 0.006
		10Hz–5kHz	0.10 + 0.04	0.10 + 0.04	0.10 + 0.04	0.015 + 0.006
		5kHz–10kHz	0.20 + 0.25	0.20 + 0.25	0.20 + 0.25	0.030 + 0.006
	1.000000A	3Hz–5Hz	1.10 + 0.06	1.10 + 0.06	1.10 + 0.06	0.100 + 0.006
		5Hz–10Hz	0.35 + 0.06	0.35 + 0.06	0.35 + 0.06	0.035 + 0.006
		10Hz–5kHz	0.15 + 0.06	0.15 + 0.06	0.15 + 0.06	0.015 + 0.006
		5kHz–10kHz	0.35 + 0.70	0.35 + 0.70	0.35 + 0.70	0.030 + 0.006
		5Hz–10Hz	0.35 + 0.08	0.35 + 0.10	0.35 + 0.10	0.035 + 0.008
		10Hz–5kHz	0.15 + 0.08	0.15 + 0.10	0.15 + 0.10	0.015 + 0.008

NOTE: [1] Specifications are for 90-minute warm-up, slow ac filter and sine wave input.

[2] 10% overrange on all ranges.

[3] Relative to calibration standards.

[4] Specifications are for sine wave input >5% of range. For inputs from 1% to 5% of range and <50 kHz, add 0.1% of range additional error. For 50 kHz to 100 kHz, add 0.13% of range.

[5] Specifications are for sine wave input >5% of range. For inputs from 1% to 5% of range, add 0.1% of range additional error. Specifications are typical values for 200  $\mu$ A, 2 mA and 1 A ranges when frequency is >1 kHz.

## Measuring Characteristics

True RMS AC Voltage	
Measurement Method	AC-coupled True-RMS -- measure the ac component of input with up to 300 V DC bias on any range.
Crest Factor	≤ 5 at full range
Input Impedance	1 MΩ ± 2%, in parallel with <150 pF capacitance on any range
Input Protection	300 V rms on all ranges
AC Filter Bandwidth	Slow: 3 Hz – 300 kHz Medium: 20 Hz – 300 kHz Fast: 200 Hz – 300 kHz
CMRR (common mode rejection ratio)	70 dB, for the 1 kΩ unbalance in LO lead, <60 Hz common mode signal frequency, ±300 VDC peak maximum.
True RMS AC Current	
Measurement Method	Direct coupled to the fuse and shunt; AC-coupled True RMS measurement (measure the AC component).
Crest Factor	≤ 3 at full range
Max. Input	DC + AC current peak value <300% of range. Current with DC current component <1 A rms.
Shunt Resistor	100 Ω for 200 μA, 2 mA 1 Ω for 20 mA, 200 mA 0.1 Ω for 1 A

### Settling Time Considerations

The default measurement delay of the multimeter can ensure the correctness of the first readings of most of the measurements. Make sure the RC circuit of input terminal has been fully settled (about 1 s) before accurate measurement.

## Frequency and Period Characteristics

Accuracy Specifications: ± (% of reading)<sup>[1][2]</sup>

Function	Range	Frequency Range	24 Hour <sup>[3]</sup> T <sub>CAL</sub> °C ± 1°C	90 Day T <sub>CAL</sub> °C ± 5°C	1 Year T <sub>CAL</sub> °C ± 5°C	Temperature Coefficient 0°C to ( T <sub>CAL</sub> °C –5°C ) ( T <sub>CAL</sub> °C +5°C ) to 50°C
Frequency, Period	200mV–300V	3 Hz–5 Hz	0.07	0.07	0.07	0.005
		5 Hz–10 Hz	0.04	0.04	0.04	0.005
		10 Hz–40 Hz	0.02	0.02	0.02	0.001
		40 Hz–300 kHz	0.005	0.006	0.007	0.001
		300 kHz–1 MHz	0.005	0.006	0.007	0.001

Additional Low Frequency Errors: (% of reading)

Frequency	Gate Time (Resolution)			
	1s ( 0.1ppm )	0.1s ( 1ppm )	0.01s ( 10ppm )	0.001s ( 100ppm )
3 Hz–5Hz	0	0.12	0.12	0.12
5 Hz–10Hz	0	0.17	0.17	0.17
10 Hz–40Hz	0	0.20	0.20	0.20
40 Hz–100Hz	0	0.06	0.21	0.21
100 Hz–300Hz	0	0.03	0.21	0.21
300 Hz–1 kHz	0	0.01	0.07	0.07
>1kHz	0	0	0.02	0.02

NOTE: [1] Specifications are for 90 minutes warm-up and 1 s gate time.

[2] For frequency ≤ 300 kHz, the specification is for AC input voltage of 10% to 110% of range. For frequency >300 kHz, the specification is for AC input voltage of 20% to 110% of range. The maximum input is limited to 750 Vrms or 8 × 10<sup>7</sup> Volts-Hz (whichever is less). 200 mV range is full range input or input that is larger than the full range.

For 20 mV to 200 mV inputs, multiply % of reading error by 10.

[3] Relative to calibration standards.

## Measuring Characteristics

Frequency and Period	
Measurement Method	Reciprocal-counting technique, AC-coupled input using the AC voltage function.
Input Impedance	1 MΩ ± 2%, in parallel with <150 pF capacitance on any range
Input Protection	300 Vrms on all ranges

### Measurement Considerations

All frequency counters are susceptible to error when measuring low-voltage, low-frequency signals. Shielding inputs from external noise pickup is critical for minimizing measurement errors.

### Settling Considerations

Errors will occur when attempting to measure the frequency or period of an input following a dc offset voltage change. The input blocking RC time constant must be allowed to fully settle (about 1 s) before the most accurate measurements are possible.

## Temperature Characteristics

Accuracy Specifications<sup>[1]</sup>

Function	Probe Type	Type	Optimum Range	1 Year $T_{CAL}^{\circ}C \pm 5^{\circ}C$	Temperature Coefficient 0°C to ( $T_{CAL}^{\circ}C - 5^{\circ}C$ ) ( $T_{CAL}^{\circ}C + 5^{\circ}C$ ) to 50°C
Temperature	RTD <sup>[2]</sup> (R0 is within 49 $\Omega$ and 2.1 k $\Omega$ )	$\alpha=0.00385$	-200°C – 660°C	0.16°C	0.01°C
		$\alpha=0.00389$	-200°C – 660°C	0.17°C	0.01°C
		$\alpha=0.00391$	-200°C – 660°C	0.14°C	0.01°C
		$\alpha=0.00392$	-200°C – 660°C	0.15°C	0.01°C
	Thermal Resistance	2.2 k $\Omega$	-40°C – 150°C	0.08°C	0.002°C
		3 k $\Omega$	-40°C – 150°C	0.08°C	0.002°C
		5 k $\Omega$	-40°C – 150°C	0.08°C	0.002°C
		10 k $\Omega$	-40°C – 150°C	0.08°C	0.002°C
		30 k $\Omega$	-40°C – 150°C	0.08°C	0.002°C
	Thermocouple <sup>[3]</sup>	B	0°C – 1820°C	0.76°C	0.14°C
		E	-270°C – 1000°C	0.5°C	0.02°C
		J	-210°C – 1200°C	0.5°C	0.02°C
		K	-270°C – 1372°C	0.5°C	0.03°C
		N	-270°C – 1300°C	0.5°C	0.04°C
		R	-50°C – 1768.1°C	0.5°C	0.09°C
		S	-50°C – 1768.1°C	0.6°C	0.11°C
T	-270°C – 400°C	0.5°C	0.03°C		

NOTE: [1] Specifications are for 90 minutes warm-up. Probe error excluded.

[2] Specification is for 4WR resistance measurement.

[3] Relative to cold junction temperature, accuracy is based on ITS-90. Built-in cold junction temperature refers to the temperature of the connector inside the terminal block and its accuracy is  $\pm 2.5^{\circ}C$ .

## Measuring Characteristics

Thermocouple	
Conversion	ITS-90 software compensation
Reference Junction Type	Internal, Fixed, or External
T/C Check	Selectable per channel. When the channel resistance is >5k $\Omega$ , it is considered as Open.
RTD	
Alpha	= 0.00385 (DIN/IEC 751): using ITS-90 software compensation; = 0.00389, 0.00391 or 0.00392: using IPTS-68 software compensation
Thermistor	
	44004, 44007, 44006 series

### Measurement Considerations

The built-in cold junction temperature tracks the temperature inside the terminal box. The change of temperature in the terminal box might cause additional error. When using the built-in cold junction compensation, connect the sensor terminal of the thermocouple to the terminal box and warm it up for more than 3 minutes to minimize the error.

## Module Specifications

MC3120/MC3132/MC3164/MC3324/MC3416/MC3648

General	Multiplexer				Actuator	Matrix
	MC3120	MC3132	MC3164	MC3324	MC3416	MC3648
Number of Channels	20	32	64	20 Voltage+4 Current	16	4 × 8
	2-wire mode or 4-wire mode <sup>[1]</sup>	2-wire mode or 4-wire mode <sup>[1]</sup>	1-wire mode <sup>[2]</sup>	2-wire mode or 4-wire mode <sup>[3]</sup>	SPDT	2-wire mode
Connect to DMM Module?	Yes	Yes	Yes	Yes	No	No
Scanning Speed <sup>[4]</sup>	60Ch/s	60Ch/s	60Ch/s	60Ch/s	—	—
Open/Close Speed	200Ch/s	200Ch/s	200Ch/s	200Ch/s	200Ch/s	200Ch/s
Maximum Input						
Voltage (DC, AC rms)	300Vrms	300Vrms	300Vrms	300Vrms	300Vrms	300Vrms
Current (DC, AC rms)	1Arms	1Arms	1Arms	1Arms	2Arms	1Arms
Power (W, VA)	50VA	50VA	50VA	50VA	60VA	50VA
Isolation (ch-ch, ch-earth) (DC, AC rms)	300Vrms	300Vrms	300Vrms	300Vrms	300Vrms	300Vrms
DC Characteristics						
Offset Voltage	5uV	5uV	5uV	5uV	<3uV	5uV
Initial Closed Channel Resistance	<1Ω	<1Ω	<1Ω	<1Ω	<0.1Ω	<1Ω
Isolation (ch-ch, ch-earth)	>10GΩ	>10GΩ	>10GΩ	>10GΩ	>10GΩ	>10GΩ
AC Characteristics						
Bandwidth	1MHz	1MHz	1MHz	1MHz	1MHz	1MHz
Ch-Ch Cross Talk (dB) <sup>[5]</sup> 1MHz	-45	-45	-18 <sup>[6]</sup>	-45	-15	-18
Capacitance HI-LO	100pF	100pF	100pF	100pF	<500pF	100pF
Capacitance LO-Earth	200pF	200pF	200pF	200pF	<200pF	200pF
Volt-Hertz Limit	10 <sup>8</sup>	10 <sup>8</sup>	10 <sup>8</sup>	10 <sup>8</sup>	10 <sup>8</sup>	10 <sup>8</sup>
Other						
T/C Cold Junction Accuracy (Typical)	0.8°C	0.8°C	0.8°C <sup>[7]</sup>	0.8°C	—	—
Switch Life (No Load) (Typical)	100M	100M	100M	100M	100M	100M
Switch Life (Rated Load) (Typical) <sup>[8]</sup>	100K	100K	100K	100K	100K	100K
Operating Temperature	0°C – 55°C	0°C – 55°C	0°C – 55°C	0°C – 55°C	0°C – 55°C	0°C – 55°C
Storage Temperature	-20°C – 70°C	-20°C – 70°C	-20°C – 70°C	-20°C – 70°C	-20°C – 70°C	-20°C – 70°C
Humidity (non-condensing)	40°C / 80% RH	40°C / 80% RH	40°C / 80% RH	40°C / 80% RH	40°C / 80% RH	40°C / 80% RH

NOTE: [1] 20 channel multiplexer can be used as 20 2-wire or 10 4-wire measurement channels and 32 channel multiplexer can be used as 32 2-wire or 16 4-wire measurement channels.

[2] 64 channel multiplexer share a Common Low for two banks of 32 channels.

[3] 24 Channel multiplexer can be configured as 20 2-wire voltage channels or 10 4-wire voltage channels in addition to the 4 current channels.

[4] Integration time: 0.02PLC, channel delay: 0, auto zero: off, alarm: off, scaling: off, data to internal memory (disconnect the communication of the LAN, USB, GPIB or RS232 interface), the results are measured under the DCV function.

[5] 50Ω load.

[6] Isolation within banks is -40dB.

[7] Specifications are for the LO setting and not the temperature of the cold terminal.

[8] Applies to resistive loads only.

## MC3534

Digital Input/Output (DIO)					
Port 1,2,3,4	8-bit, input or output, non-isolated				
Type	Vin(L)	Vin(H)	Vout(L)	Vout(H)	Vin(H) Max
TTL	<0.8V	>2.0V	<0.2V@I <sub>out</sub> =-500mA	>4.8V@I <sub>out</sub> =1mA	<42V with external open drain pull-up
5V CMOS	<1.5V	>3.5V	<0.2V@I <sub>out</sub> =-500mA	>4.8V@I <sub>out</sub> =1mA	
3.3V CMOS	<1.0V	>2.3V	<0.2V@I <sub>out</sub> =-500mA	>3.15V@I <sub>out</sub> =1mA	
2.5V CMOS	<0.75V	>1.75V	<0.2V@I <sub>out</sub> =-500mA	>2.35V@I <sub>out</sub> =1mA	
User defined	Threshold-0.3V	Threshold+0.3V	<0.2V@I <sub>out</sub> =-500mA	>(Level-0.2V)@I <sub>out</sub> =1mA	
Alarming	Match or mismatch, maskable				Match or mismatch, maskable
Speed	4ms (Max) alarm sampling				4ms (Max) alarm sampling
Latency	5ms				5ms
Read/Write Speed	100/s				100/s
Totalizer Input (TOT)					
	High Speed (TOT1,TOT2)		Normal Speed (TOT3,TOT4)		
Maximum Count	2 <sup>32</sup> -1		2 <sup>32</sup> -1		
Totalizer Input	10MHz (max), rising or falling edge, programmable		100kHz (max), rising or falling edge, programmable		
Signal Level	CMOS 3.3V,5V tolerable		1Vp-p(min),42Vpk(max), Vcm=-12V~+12V		
Threshold	Fixed at CMOS 3.3V		-12V~+12V, Programmable		
Gated Input	CMOS 3.3V-Hi, CMOS 3.3V-Lo or none, 5V tolerance		CMOS 3.3V-Hi, CMOS 3.3V-Lo or none, 5V tolerance		
Count Reset	Manual or Read + Reset		Manual or Read + Reset		
Read Speed	100/s		100/s		
Analog Voltage Output (DAC)					
DAC 1,2,3,4	± 12V, non-isolated (earth referenced)				
Resolution	1mV				
I <sub>out</sub>	10mA max				
Setting Time	1ms to 0.01 % of output				
Accuracy	± ( % of output + mV)				
1 year ± 5°C	0.25%+20mV				
Temp Coefficient	± (0.015%+1mV)/°C				

## General Specifications

Display	4.3 inches
Power Supply	AC 100V – 120V, 45Hz – 440Hz AC 200V – 240V, 45Hz – 66Hz Detect the power frequency automatically at power-on, 400 Hz defaults to 50 Hz
Power Consumption	25 VA Max
Working Environment	Full accuracy for 0°C to 50°C Full accuracy to 80% R.H. at 40°C Non-coagulation
Storage Temperature	-40°C to 70°C
Operation Altitude	Up to 2000 meters
Safety	IEC 61010-1; EN 61010-1; UL 61010-1; CAN/CSA-C22.2 No. 61010-1 Measurement CAT I 300V Pollution Degree 2
EMC	EN 61326-1
Weight	About 5.7 kg (without package)
Dimension	(height × width × length): 159.0mm × 239.0mm × 373.4mm
Remote Interface	GPiB, 10/100Mbit LAN, USB 2.0 Full Speed Device & Host (support USB storage device), RS232
Programming Language	SCPI
LXI Compatibility	LXI Core 2011 Device, Version 1.4
Warm-up Time	90 minutes